

# “Snow Loading” of Enclosure Mesh 0.28mm Ø Stainless Steel



## Test Setup

A 1m x 1m piece of knitted mesh, produced from 0.28mm diameter stainless steel wire, and with a stitch pattern as shown in Figure 1, was attached to a test frame structure shown in Figure 2.

The knitted mesh was secured to the frame on two parallel sides and left unconstrained on the others. A thin (unconstrained) plastic sheet was then placed over the knitted mesh.

Sand, used as a substitute for snow, was then incrementally added and removed, and the loaded and unloaded deflection or “sag” of the knitted mesh was measured at three points L, C and R under the mesh in the unconstrained axis.

## Results

The deflection data sets generated from the loading and unloading of the sand to/from the knitted mesh sheets are shown in Figure 3 and Figure 4.

200kg of sand was successfully loaded onto the 1m x 1m sheet of knitted mesh with no points of failure being detected after its removal, either in the main sheet of mesh or at its fixing points on the test structure. The sheet of mesh failed during further loading at ~203kg.

In order to assess what this might mean in real-world snow-loading terms, 200kg of sand was estimated at various heights of snow according to data presented by Paterson W.S.B. (1994) and is presented in Table 1.

Table 1. Estimate of equivalent height of snow for 200kg sand loaded onto 0.28mm diameter wire, 1m x 1m knitted mesh.

Type of Snow	Density (kg/m <sup>3</sup> )	Height of Snow (mm) ~ 200kg of Sand
New snow	50-70	2850 - 4000
Damp new snow	100-200	1000 - 2000
Settled snow	200-300	665 - 1000
Wind-packed snow	350-400	500 - 570
Firn*	400-830	240 - 500
Very wet snow + Firn	700-800	250 - 285
Glacier ice	830-917	220 - 240

\*Firn: Granular and partially compacted snow that has passed through one summer's melting season but has not yet turned to glacial ice.

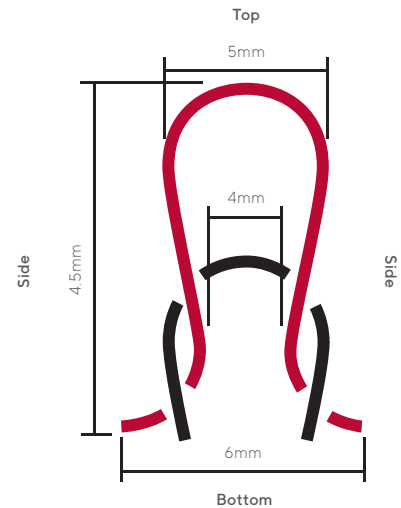

Figure 1. Schematic diagram of stitch pattern used in this test with 0.28mm diameter wire (not to scale).

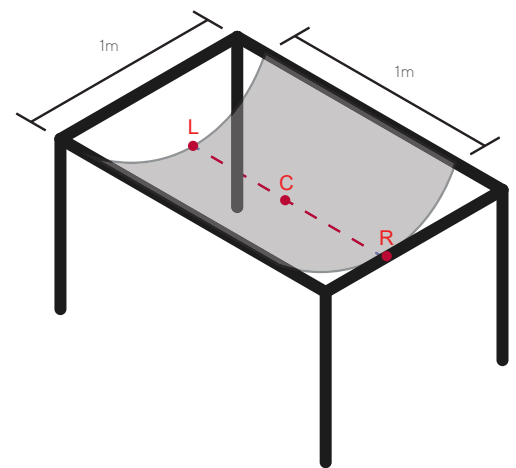

Figure 2. Schematic diagram of structure used to constrain wire mesh under test, indicating measuring points (not to scale)

Tel: +44 (0) 1352 717 600

Email: sales@knitmeshtechnologies.com

Fax: +44 (0) 1352 714 909

Coast Road, Greenfield, Flintshire, CH8 9DP United Kingdom



Protecting People, Property and our Planet

# “Snow Loading” of Enclosure Mesh 0.28mm Ø Stainless Steel

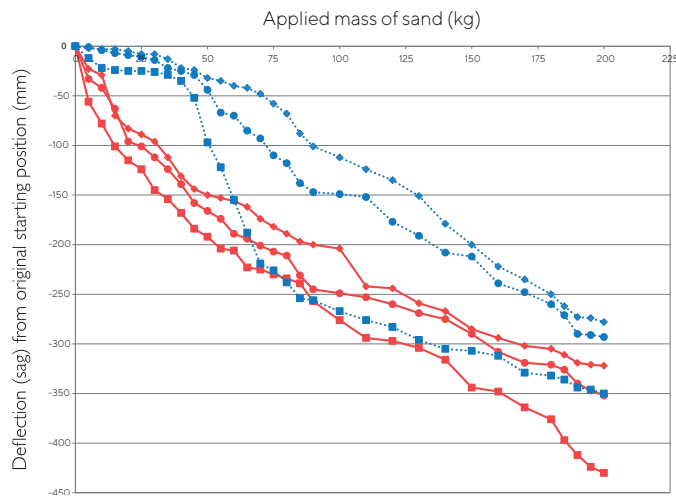

**Figure 3.** The loaded and unloaded (relaxed) deflections of the knitted wire mesh sheet as increasing amounts of sand are added and removed. This chart plots data for a knitted wire mesh sheet which is aligned so that the sheet is fixed to the test structure “with the stitch”.

— Point L  
— Point C  
— Point R  
... Point L  
... Point C  
... Point R

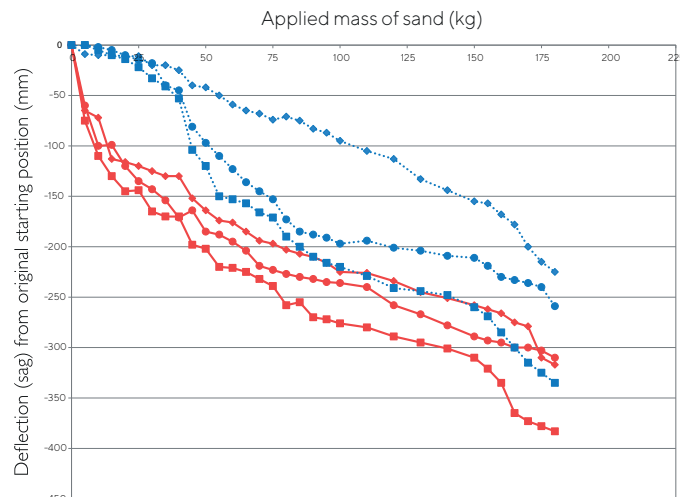

**Figure 4.** The loaded and unloaded (relaxed) deflections of the knitted wire mesh sheet as increasing amounts of sand are added and removed. This chart plots data for a knitted wire mesh sheet which is aligned so that the sheet is fixed to the test structure “against the stitch”.

— Point L  
— Point C  
— Point R  
... Point L  
... Point C  
... Point R

In Figure 3 and Figure 4, the solid red lines correspond to the loaded deflection, whilst the dotted blue lines correspond to the unloaded or relaxed deflection.

## Notes: “with the stitch” and “against the stitch”

“With the stitch” - the knitted wire mesh was constrained along its top and bottom edges (see Figure 1)

“Against the stitch” - the knitted wire mesh was constrained along its side edges (also Figure 1)

## References:

Paterson W.S.B. “The Physics of Glaciers”, Butterworth Heinemann, 1994

Tel: +44 (0) 1352 717 600  
Email: sales@knitmesstechnologies.com  
Fax: +44 (0) 1352 714 909  
Coast Road, Greenfield, Flintshire, CH8 9DP United Kingdom

