

“Snow Loading” of Enclosure Mesh 0.35mm Ø Stainless Steel Wire



Test Setup

A 1m x 1m piece of knitted mesh wire, made from 0.35mm diameter stainless steel wire, and with a stitch pattern as shown in Figure 1, was attached to a test frame structure shown in Figure 2. The mesh was secured to the frame on two parallel sides, and left unconstrained on the others. A thin (unconstrained) plastic sheet was then placed over the wire mesh. Sand, used as a substitute for snow, was then incrementally added and removed, and the loaded and unloaded deflection or “sag” of the mesh was measured at three points L, C and R under the mesh in the unconstrained axis.

Results

The deflection data sets generated from the loading and unloading of the sand to/from the knitted wire mesh sheets are shown in Figure 3 and Figure 4. 500kg of sand was successfully loaded onto the 1m x 1m sheet of knitted wire mesh, with no points of failure being detected after its removal either in the main sheet of mesh, or at its fixing points on the test structure. No more sand was available to continue testing to failure. In order to assess what this might mean in real-world snow-loading terms 500kg of sand was estimated as a height of snow according to data presented by Paterson W.S.B. (1994), and is presented in Table 1.

Table 1. Estimate of equivalent height of snow for 500kg sand loaded onto 0.35mm diameter wire, 1m x 1m knitted wire mesh.

Type of Snow	Density (kg/m ³)	Height of Snow (mm) ~ 750kg of Sand
New snow	50-70	7140 - 10000
Damp new snow	100-200	2500 - 5000
Settled snow	200-300	1660 - 2500
Wind-packed snow	350-400	1250 - 1430
Firn*	400-830	600 - 1250
Very wet snow + Firn	700-800	625 - 710
Glacier ice	830-917	545 - 600

*Firn: Granular and partially compacted snow that has passed through one summer’s melting season but has not yet turned to glacial ice.

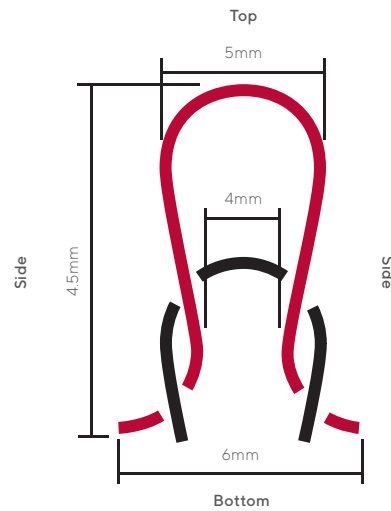

Figure 1. Schematic diagram of stitch pattern used in this test with 0.35mm diameter wire (not to scale).

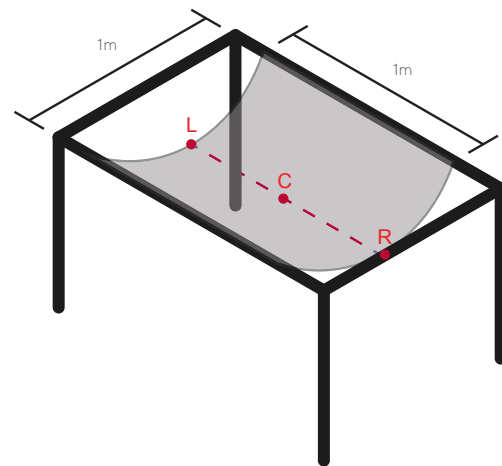

Figure 2. Schematic diagram of structure used to contain wire mesh under test, indicating measuring points (not to scale)

0.50mm Ø Stainless Steel Wire

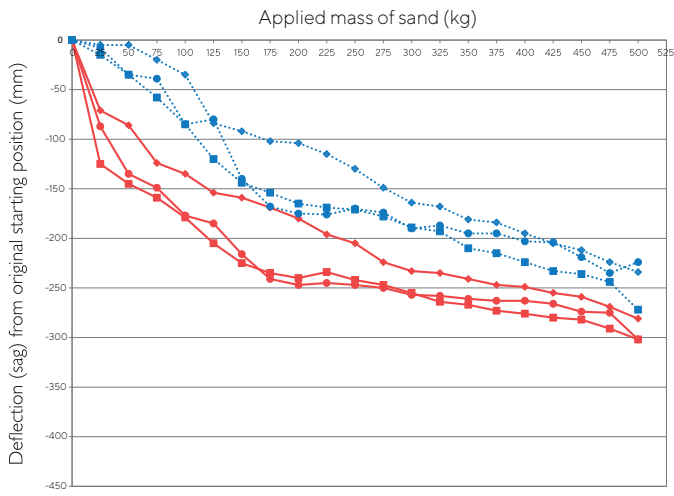

Figure 3. The loaded and unloaded (relaxed) deflections of the knitted wire mesh sheet as increasing amounts of sand are added and removed. This chart plots data for a knitted wire mesh sheet which is aligned such that the sheet is fixed to the test structure "with the stitch".

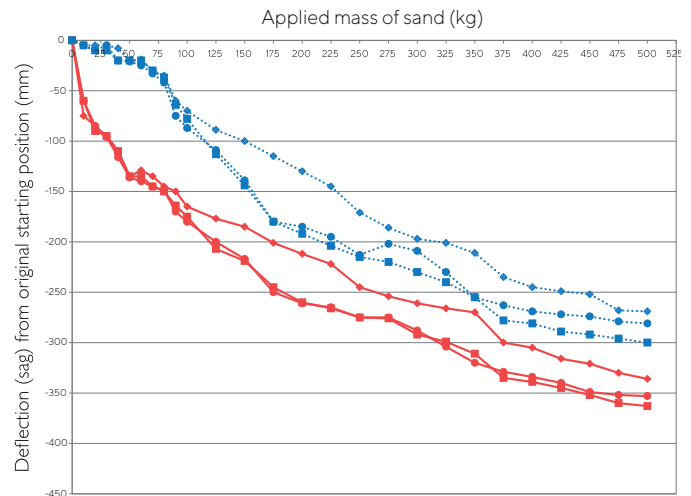

Figure 4. The loaded and unloaded (relaxed) deflections of the knitted wire mesh sheet as increasing amounts of sand are added and removed. This chart plots data for a knitted wire mesh sheet which is aligned such that the sheet is fixed to the test structure "against the stitch".

In Figure 3 and Figure 4, the solid red lines correspond to the loaded deflection, whilst the dotted blue lines correspond to the unloaded or relaxed deflection.

Notes: "with the stitch" and "against the stitch"

"With the stitch" - the knitted wire mesh was constrained along its top and bottom edges (see Figure 1)

"Against the stitch" - the knitted wire mesh was constrained along its side edges (also Figure 1)

References:

Paterson W.S.B. "The Physics of Glaciers", Butterworth Heinemann, 1994

Tel: +44 (0) 1352 717 600
 Email: sales@knitmesstechnologies.com
 Fax: +44 (0) 1352 714 909
 Coast Road, Greenfield, Flintshire, CH8 9DP United Kingdom

