

“Snow-Loading” of Enclosure Mesh

0.28mm Ø Stainless Steel Wire

Test Setup

A 1m x 1m piece of knitted mesh wire, made from 0.28mm diameter stainless steel wire, and with a stitch pattern as shown in Figure 1, was attached to a test frame structure shown in Figure 2. The mesh was secured to the frame on two parallel sides, and left unconstrained on the others. A thin (unconstrained) plastic sheet was then placed over the wire mesh. Sand, used as a substitute for snow, was then incrementally added and removed, and the loaded and unloaded deflection or “sag” of the mesh was measured at three points L, C and R under the mesh in the unconstrained axis.

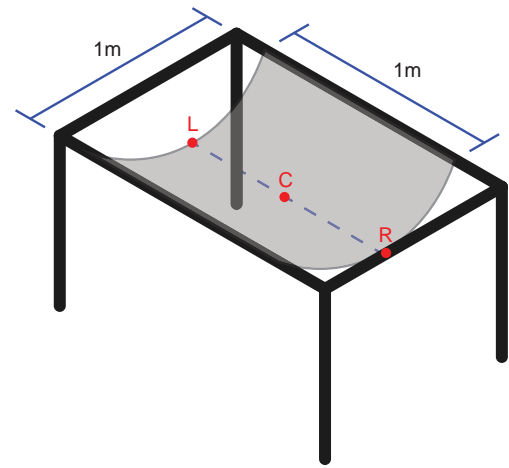
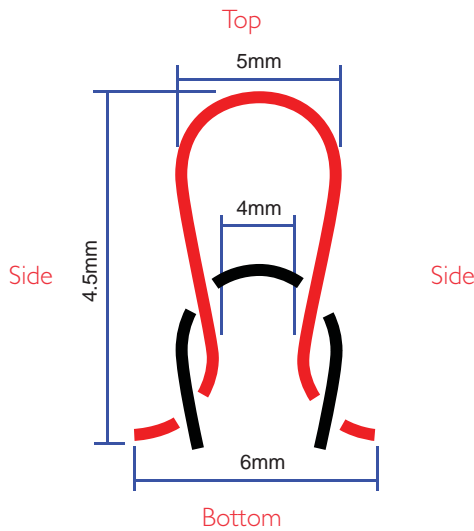

Figure 1. Schematic diagram of stitch pattern used in this test with 0.28mm diameter wire (not to scale).

Figure 2. Schematic diagram of structure used to constrain wire mesh under test, indicating measuring points (not to scale)

Results

The deflection data sets generated from the loading and unloading of the sand to/from the knitted wire mesh sheets are shown in Figure 3 and Figure 4. 200kg of sand was successfully loaded onto the 1m x 1m sheet of knitted wire mesh, with no points of failure being detected after its removal either in the main sheet of mesh, or at its fixing points on the test structure. The sheet of mesh failed during further loading at ~203kg. In order to assess what this might mean in real-world snow-loading terms 200kg of sand was estimated as a height of snow according to data presented by Paterson W.S.B. (1994), and is presented in Table 1.

Table 1. Estimate of equivalent height of snow for 200kg sand loaded onto 0.28mm diameter wire, 1m x 1m knitted wire mesh.

Type of Snow	Density (kg/m ³)	Height of Snow (mm) ~ 200kg of Sand
New snow	50-70	2850 - 4000
Damp new snow	100-200	1000 - 2000
Settled snow	200-300	665 - 1000
Wind-packed snow	350-400	500 - 570
Firn*	400-830	240 - 500
Very wet snow + Firn	700-800	250 - 285
Glacier ice	830-917	220 - 240

*Firn: Granular and partially compacted snow that has passed through one summer's melting season but has not yet turned to glacial ice.

“Snow-Loading” of Enclosure Mesh 0.28mm Ø Stainless Steel Wire

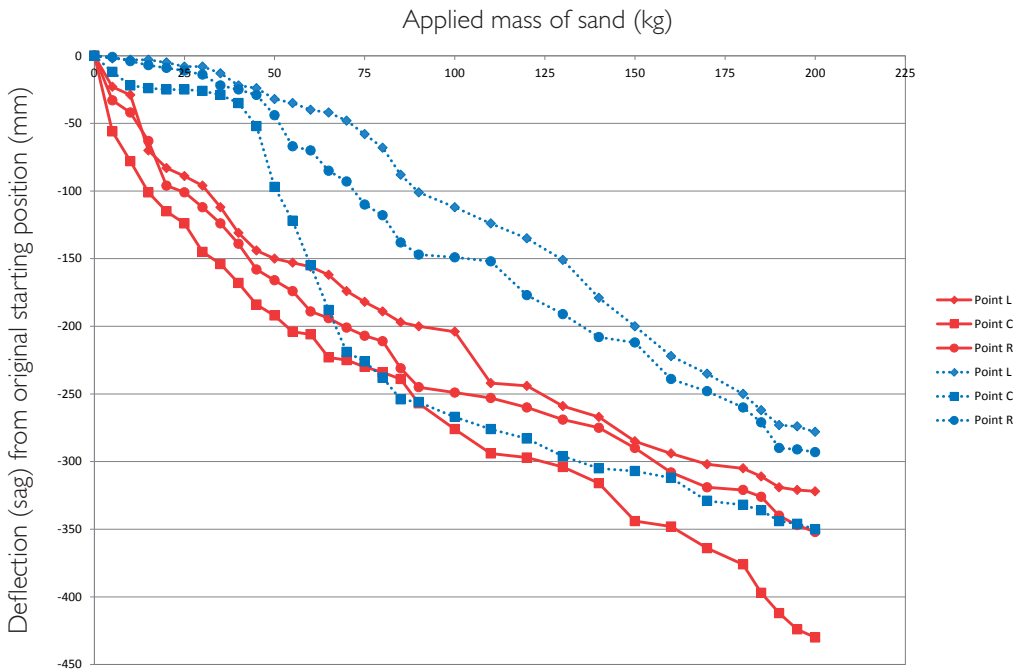

Figure 3. The loaded and unloaded (relaxed) deflections of the knitted wire mesh sheet as increasing amounts of sand are added and removed. This chart plots data for a knitted wire mesh sheet which is aligned such that the sheet is fixed to the test structure “with the stitch”.

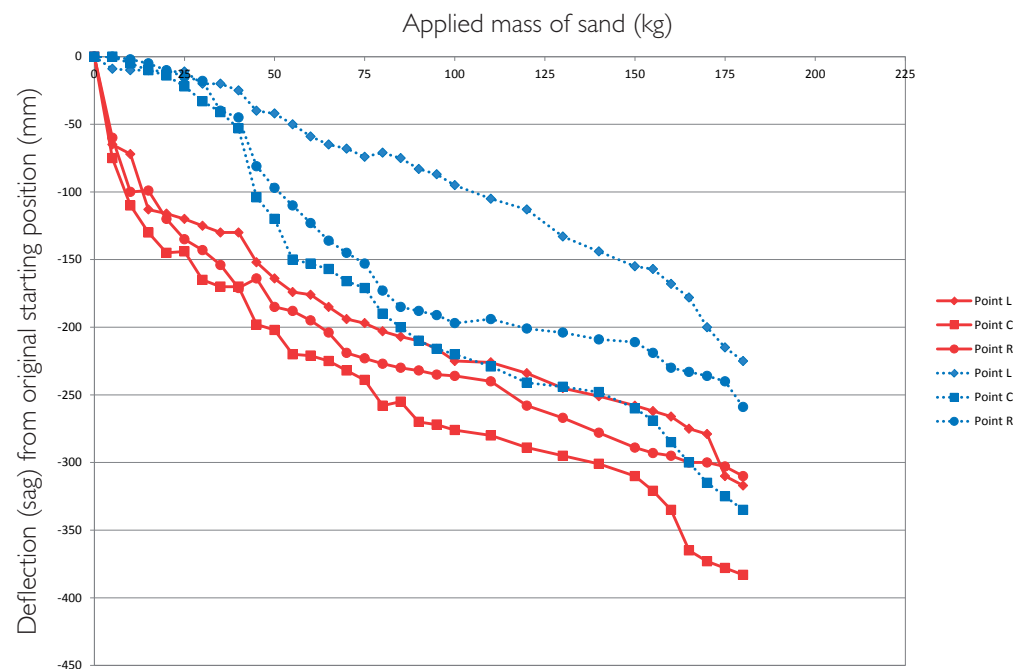

Figure 4. The loaded and unloaded (relaxed) deflections of the knitted wire mesh sheet as increasing amounts of sand are added and removed. This chart plots data for a knitted wire mesh sheet which is aligned such that the sheet is fixed to the test structure “against the stitch”.

In Figure 3 and Figure 4, the solid red lines correspond to the loaded deflection, whilst the dotted blue lines correspond to the unloaded or relaxed deflection.

Notes: “with the stitch” and “against the stitch”

“With the stitch” - the knitted wire mesh was constrained along its top and bottom edges (see Figure 1)

“Against the stitch” - the knitted wire mesh was constrained along its side edges (also Figure 1)

References:

Paterson W.S.B. “The Physics of Glaciers”, Butterworth-Heinemann, 1994

Customer Support

KnitMesh Technologies

Greenfield, Flintshire, United Kingdom CH8 9DP

T +44 (0) 1352 717 600 F +44 (0) 1352 714 909 E sales@knitmeshtechologies.com

Issue No 03 (4/14)

The information provided above is supplied in good faith and believed to be correct. This information is supplied upon the condition that persons receiving this will make their own determination as to its suitability for their purposes prior to use. KnitMesh makes no representations or warranties, either expressed or implied with respect to the information or the product to which this information refers.



**KnitMesh
Technologies®**

Protecting People, Property and Our Planet

www.knitmeshtechologies.com